

KEY FEATURES

- Open Frame ITE Switching Power Supply
- Universal Input Range 90-264VAC, 47-63 Hz
- Operating Ambient Temperature Range -40°C to +80°C
- I/O Isolation 3000VAC
- No Load Power Consumption < 0.1W
- High Efficiency up to 90%
- Ultra Compact Size: 3.0 x 2.0 x 0.87 Inches
- Safety Approval to UL / IEC / EN 62368-1
- 3-Year Product Warranty



ELECTRICAL SPECIFICATIONS

All specifications valid at normal input voltage, full load and +25°C after warm-up time unless otherwise stated.

Model No.		AQF65-12S	AQF65-24S
Max Output Wattage (W)		65W	
Input	Voltage (Note 4)	90-264 VAC or 120-370 VDC	
	Frequency (Hz)	47-63 Hz	
	Current (Full load)	1500 mA max. (115 VAC) / 1000 mA max. (230 VAC)	
	Inrush Current (<2ms) (Cold Start)	50 A max. (115 VAC) / 100 A max. (230 VAC)	
	Leakage Current	0.25 mA max. (100-240 VAC)	
	No Load Power Consumption	< 0.1W (115/230 VAC)	
Output	Voltage (V.DC.)	12V	24V
	Voltage ADJ. Range	10.8~13.2V	21.6~26.4V
	Voltage Accuracy	±2%	
	Current (mA) (max.)	5410	2700
	Peak Current (mA) (10sec) (Note 2)	5960	2980
	Line Regulation (LL-HL) (typ.)	±1%	
	Load Regulation (0-100%) (typ.)	±1%	
	Maximum Capacitive Load	6000uF	1200uF
	Ripple & Noise (Full Load)	120mV	240mV
	Efficiency (at 230 VAC)	89.5%	90%
	Hold-up Time (typ)	30 ms (at 230VAC)	
Protection	Over Power Protection	Auto recovery	
	Over Voltage Protection	Zener diode clamp	
	Short Circuit Protection	Hiccup mode (automatic recovery)	
Isolation	Input-Output (V.AC)	3000VAC or 4242VDC	
Environment	Operating Temperature (Note 5)	-40°C...+80°C (with derating)	
	Storage Temperature	-40°C...+85°C	
	Temperature Coefficient	±0.05%/°C	
	Altitude During Operation (UL / IEC / EN 62368-1)	2000m	
	Humidity	60% RH	
	MTBF	>330,000 h @ 25°C (MIL-HDBK-217F)	
	Vibration	IEC60068-2-6 (10~500Hz, 2G 10min./1cycle, 60min. each along X, Y, Z axes)	
	Shock	IEC60068-2-27	
Physical	Dimensions (L x W x H)	3.0 x 2.0 x 0.87 Inches (76.2 x 50.8 x 22.0 mm) Tolerance ±0.5 mm	
	Weight	88 g	
	Cooling Method	Free air convection	
Safety	Approval	UL / IEC / EN 62368-1	
EMC	EMI (Conducted & Radiated Emission)	EN 55032 class B	
	EMS (Noise Immunity)	EN 55035	

NOTE

1. Ripple & Noise are measured at 20MHz of bandwidth by using a 6" twisted pair-wire terminated with a 0.1uF & 47uF parallel capacitor.
2. 33% Duty cycle maximum within every 30 seconds. Average output power should not exceed the rated power.
3. Strongly recommend to conduct this test with DC Voltage. If customer wishes to test with AC Voltage, please disconnect all Y-Capacitors from Arch power supply.
4. Derating may be needed under low input voltages. Please check the derating curve for more details.
5. Due to varying customer application conditions, the product is tested for maximum operating temperature under full load only. For other regulatory requirements, please contact ARCH.
6. Please refer to our PDF file "AC-DC Application" on our website: www.archcorp.com.tw

DERATING

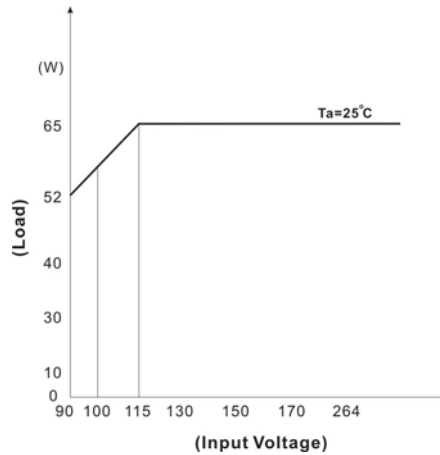
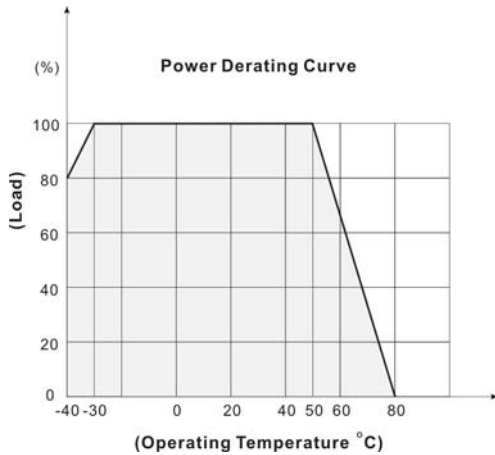

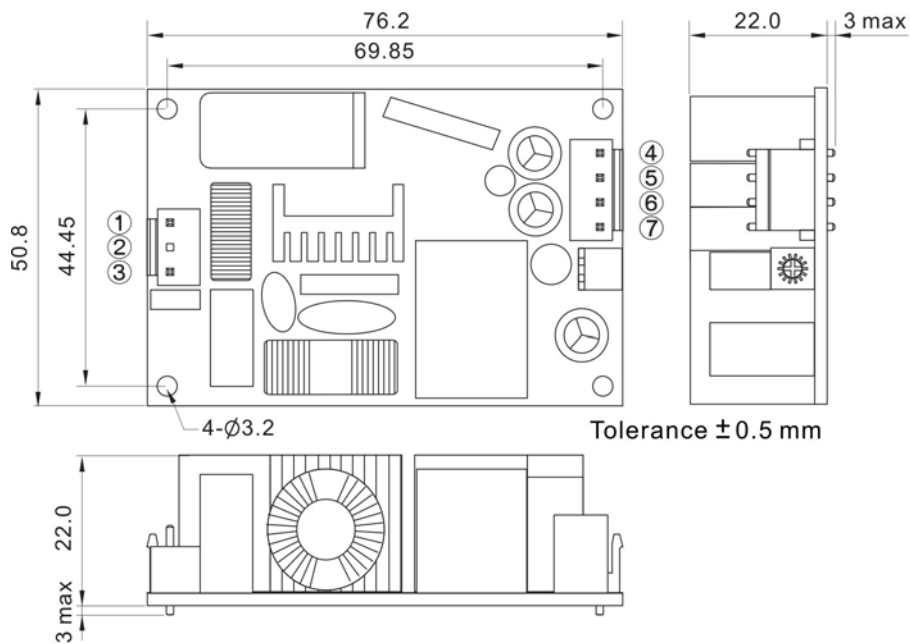
MECHANICAL DIMENSIONS (Top View)

Brands		Alex		JST	
PIN#	Single	Mating Housing	Terminal	Mating Housing	Terminal
1	AC IN (N)	9396-3	96T series	VHR-3N	SVH-41T-P1.1
2	NO PIN				
3	AC IN (L)				
4~5	+DC OUT	9396-4	96T series	VHR-4N	SVH-41T-P1.1
6~7	-DC OUT				