

CRS-1000

1000W SINGLE OUTPUT DC/DC CONVERTERS

GENERAL FEATURES:

- Designed according to EN50155
- Fire and smoke: EN45545-2 approved
- High input-output isolation
- Adjustable output voltage
- Remote inhibit
- Remote sensing
- Input & Output OK LEDs
- Output failure alarm
- Input reverse polarity protection
- ORing FET option
- Different cooling options
- Efficiency up to 94%



	24Vin 14,4V ... 30V	36Vin 21,6V ... 47V	48Vin 28,8V ... 60V	72Vin 43,2V ... 90V	110Vin 66V ... 144V
24Vout	CRS-1000-6475	CRS-1000-6487	CRS-1000-6478	CRS-1000-6481	CRS-1000-6484
48Vout	CRS-1000-6476	CRS-1000-6488	CRS-1000-6479	CRS-1000-6482	CRS-1000-6485
72Vout	CRS-1000-6490	CRS-1000-6491	Available under request	Available under request	CRS-1000-6494
110Vout	CRS-1000-6492	Available under request	Available under request	Available under request	CRS-1000-6493

Several references are subjected to special MOQs and lead times. Please consult Premium's Sales Dept. and web site.



INPUT	
Input voltage range	See table
Input undervoltage shutdown	55% to 60% Vi nom
Maximum allowed input ripple	15% Vin nom (EN50155)
OUTPUT	
Output voltage	See table
Output voltage adjustment	
Vi min = 60% Vi nom	-10% ... +0% Vo nom
Vi min = 70% Vi nom	-10% ... +15% Vo nom
Line regulation (Io = nom)	< 0,2 %
Load regulation (Vin = nom Io: 0...100%)	< 0.2 % by default < 2.5 % for ORing FET option
Ripple	< 50 mVpp
Noise (BW = 20MHz)	< 100 mVpp
Max. overvoltage protection	< 140% Vout nom
Maximum remote sense	0.3V / pole
Hold up time	10ms (Class S2 EN50155) only with option H
ENVIRONMENTAL	
Storage temperature	-40°C ... 85°C
Operating temperature range Io: 100%	-25°C ... 55°C (-40°C ... 55°C, see note-1)
Operating temperature range Io :75%	-25°C ... 70°C (-40°C ... 70°C, see note-1)
Cooling	Natural convection
Maximum Relative humidity	95% with no condensation
Shock and vibration	EN61373 Category 1 class B body mounted
MTBF (at 40°C and 75% load)	350.000h acc. to IEC61709 Cooling options R, V, D 250.000h acc. to IEC61709 Cooling option C
Service life (at 40°C and 75% load)	20 years (Option C fan maintenance at 10 years is required)
EMC	
Emission	EN61000-6-4, EN50121-3-2
Immunity	EN61000-6-2, EN50121-3-2
SAFETY	
Safety	EN62368
Dielectric strength Input-Output	3000Vac, 4200Vdc 1min.
Dielectric strength Input-Earth	1500Vac, 2100Vdc 1min.
Dielectric strength Output-Earth	1500Vac, 2100Vdc 1min.
Fire and smoke	EN45545-2:2020
MECHANICAL	
Approximate weight	< 2.5kg, < 5kg for convection cooling version
CONTROL	
Remote inhibit	Unit OFF applying: 15 ... 143 Vdc, Impedance > 27kΩ
Alarm contacts	1A @ 30Vdc, 0.3A @ 150Vdc, 0.3A @ 125Vac
Local: Input OK, Output OK	Green LEDs
PROTECTIONS	
Against overloads and short-circuits	Current limiting
Against output over-voltages	Shutdown (reset by input switch off)
Against over-temperature	Shutdown with self-recovery
Against reverse input voltage.	Input fuse (Active protection with option H)
Against input under-voltage.	Under-voltage lock-out
Against Input over-currents	Input fuse

Note-1: The unit can start up and work at an ambient temperature of -40°C with the following restrictions:

- 1) Do not handle the connection terminals below -25°C.
- 2) The output ripple can rise up to 150mVpp at -40°C



ORDERING CODES

Part Number	Input voltage [V]	Input voltage range [V]	Maximum Input current [A]	Output Power [W]	Output Voltage [V]	Output current [A]	Efficiency (Typ.) At full load [%]
CRS-1000-6475	24	14,4 - 30	78,9	1000	24	41,6	88
CRS-1000-6476	24	14,4 - 30	78,0	1000	48	20,8	89
CRS-1000-6490	24	14,4 - 30	77,2	1000	72	13,9	90
CRS-1000-6492	24	14,4 - 30	77,2	1000	110	9,8	90
CRS-1000-6487	36	21,6 - 47	51,4	1000	24	41,6	89
CRS-1000-6488	36	21,6 - 47	51,4	1000	48	20,8	90
CRS-1000-6491	36	21,6 - 47	50,9	1000	72	13,9	91
CRS-1000-6478	48	28,8 - 60	38,2	1000	24	41,6	91
CRS-1000-6479	48	28,8 - 60	37,7	1000	48	20,8	92
CRS-1000-6481	72	43,2 - 90	25,4	1000	24	41,6	91
CRS-1000-6482	72	43,2 - 90	25,2	1000	48	20,8	92
CRS-1000-6484	110	66 - 144	16,5	1000	24	41,6	92
CRS-1000-6485	110	66 - 144	16,3	1000	48	20,8	93
CRS-1000-6494	110	66 - 144	16,1	1000	72	13,9	94
CRS-1000-6493	110	66 - 144	16,1	1000	110	9,8	94

Several references are subjected to special MOQs and lead times. Please consult Premium's Sales Dept. and web site.

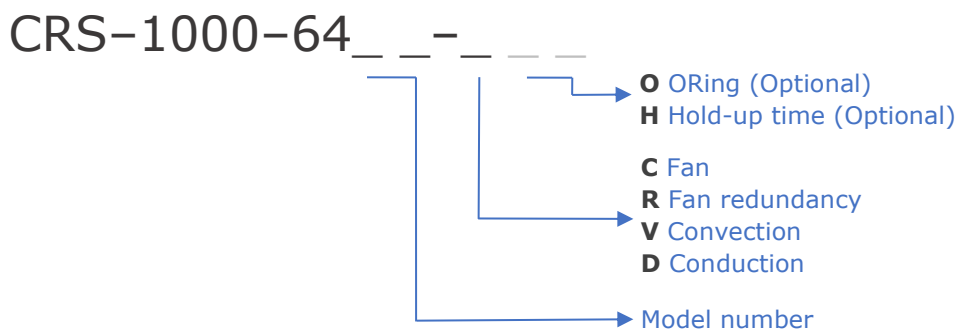

OPTIONS INFORMATION	Letter code
Fan cooling (2 fans with speed control)	C
Fan redundancy cooling (4 fans with speed control working at half speed at full load)	R
Convection cooling	V
Conduction cooling	D
Hold up time of 10ms at 1000W. Includes: <ul style="list-style-type: none"> • Active protection against input reverse polarity • Active inrush current limiter at $< 2 \cdot I_{nmax}$ (Maximum Input current) 	H
ORing FET for redundancy. Includes a passive current sharing by voltage drop $< 2.5\%$	O

Accessories must be ordered in a separate order line



Option C: Fan cooling



Option R: Fan redundancy cooling



Option V: Convection cooling

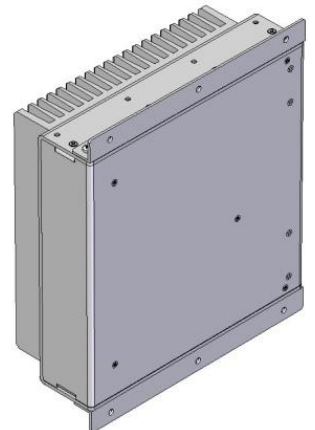
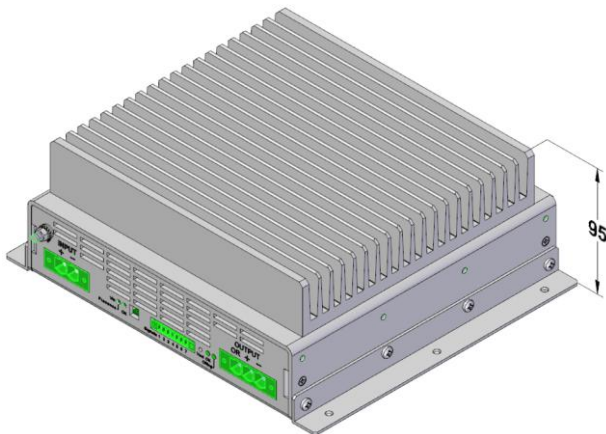

Option D: Conduction cooling

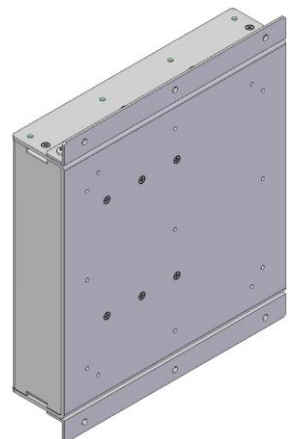
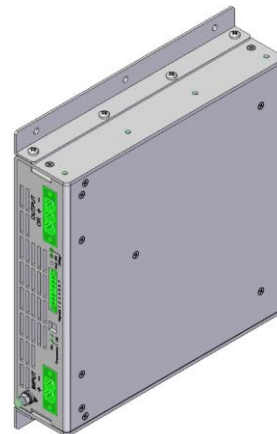
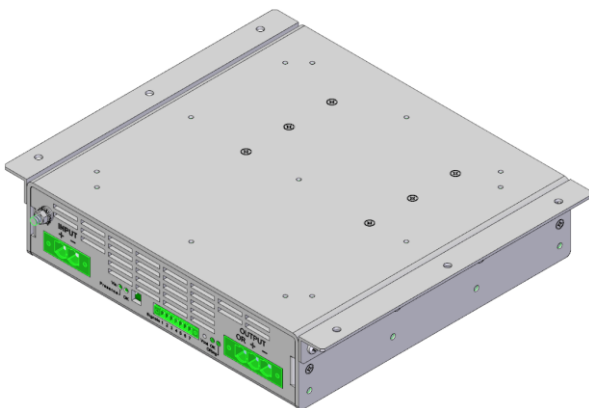

BLOCKS DIAGRAM

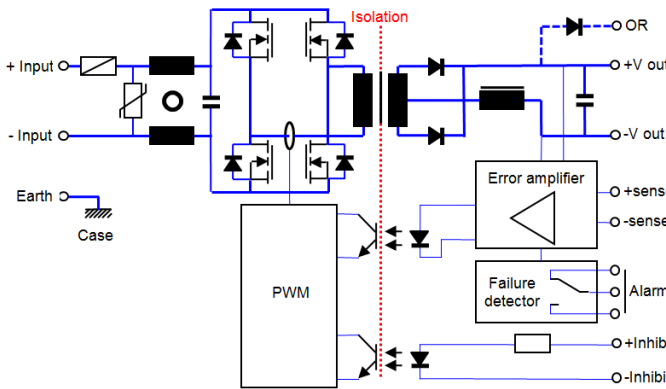

Typical output characteristic

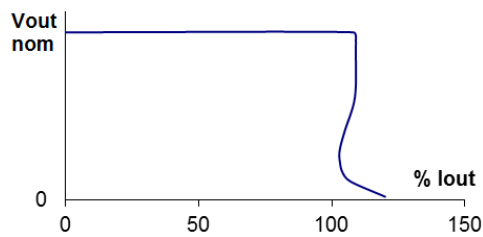

Power derating vs ambient temperature & altitude[m]

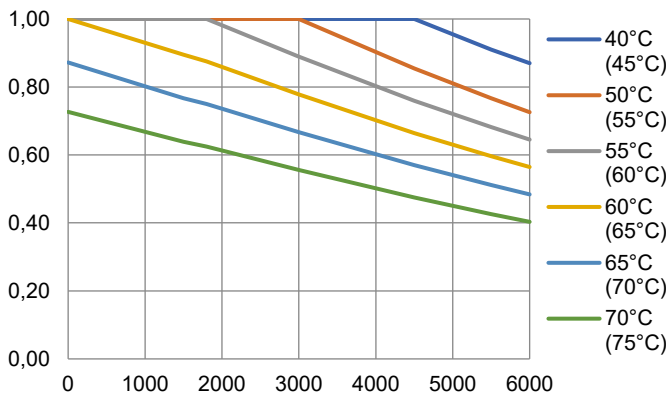

Output/Input working area

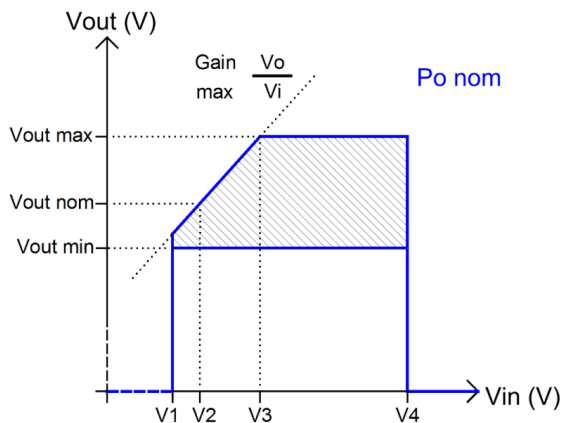

MODELS	V1	V2	V3	V4
24V input	<14.4 V	15.4 V	16.8 V	>30 V
Rest	< 0.6·Vin nom	0.6·Vin nom	0.7·Vin nom	>1.25·Vin nom

DESCRIPTION

The CRS-1000 series consists of DC-DC converters with a galvanic isolation input-output and fixed switching frequency.

For maximum regulation, the remote sensing terminals can be connected to the load. This will allow a power cable voltage drop of up to 0.3 V on each cable to be offset.

The device is protected against overloads and short-circuits by means of a current limiting circuit.

The device is also protected against reverse polarity input voltage, and the input fuse blows if an improper connection is made.

When a converter input under-voltage condition occurs, the converter is disabled, thus preventing the battery from becoming totally discharged. Once the input is within the range the unit restarts automatically.

INSTALLATION

The product has been designed to be installed on a chassis by means of the included mounting brackets.

With the option of natural convection, the heatsink fins must be mounted in vertical position. With the other cooling options there is no preferred mounting position.

With forced air options, the inlet and outlet air must be free of elements that cause an airflow reduction (the minimum recommended distance to other objects is 50mm).

It is necessary to take into account the environmental conditions of maximum temperature and altitude, since they can limit the maximum output power. See the figure "Power derating vs ambient temperature & altitude". If you have the option "R" (4 fans), the temperature values in brackets can be used. In this case the redundancy of ventilation is lost.

START-UP

Perform connection according to the figure. Use of remote sensing is not mandatory, but if this is required, use of a coaxial or a twisted-pair cable is recommended.

WARNING: If the load is connected to the tabs of remote sensing (+/-S) and the connection from the output to this load is missing the remote sensing function could be lost due to the acting of the internal fuse of protection.



Power connections (input and output)

Input & Output: Connectors for cables up to 16mm²
Earth M5 threaded stud

Signals connector

1	+ Inhibit
2	- Inhibit
3	- Remote sense
4	+ Remote sense
5	Alarm relay NC (closed when alarm)
6	Alarm relay Common
7	Alarm relay NO (open when alarm)

If several converters need to be connected in parallel, do the following:

- Set the output voltage for all converters featuring a mutual difference as small as possible.
- Join the load outputs by using cables with a cross-section no greater than the one required and of equal length.
- Do not use remote sensing.

For safety reasons, the following requirements must be complied with:

- Provide the equipment with a protective enclosure that complies with the electrical safety directives in effect within the country where the equipment is installed.
- Only replace the fuse with another fuse of the same rating and type, and only after disconnecting the converter from DC power.
- In case of installing input breaker, we recommend one with a current rating higher than the maximum input current curve C. See ORDERING CODES table.
- In case of installing input fuse, we recommend one with a current rating higher than the maximum input current type T (time lag). See ORDERING CODES table.

ALARM

The alarm can be activated by the following reasons:

- When the output voltage is lower than 80...88% of $V_{out\ nom}$.
- When there is a defective fan. In this case the LED Vin OK blinks.
- When the internal temperature reaches about 98°C; just a few degrees below the overtemperature protection shutdown. In this case the LED Vin OK also blinks.



DIMENSIONS

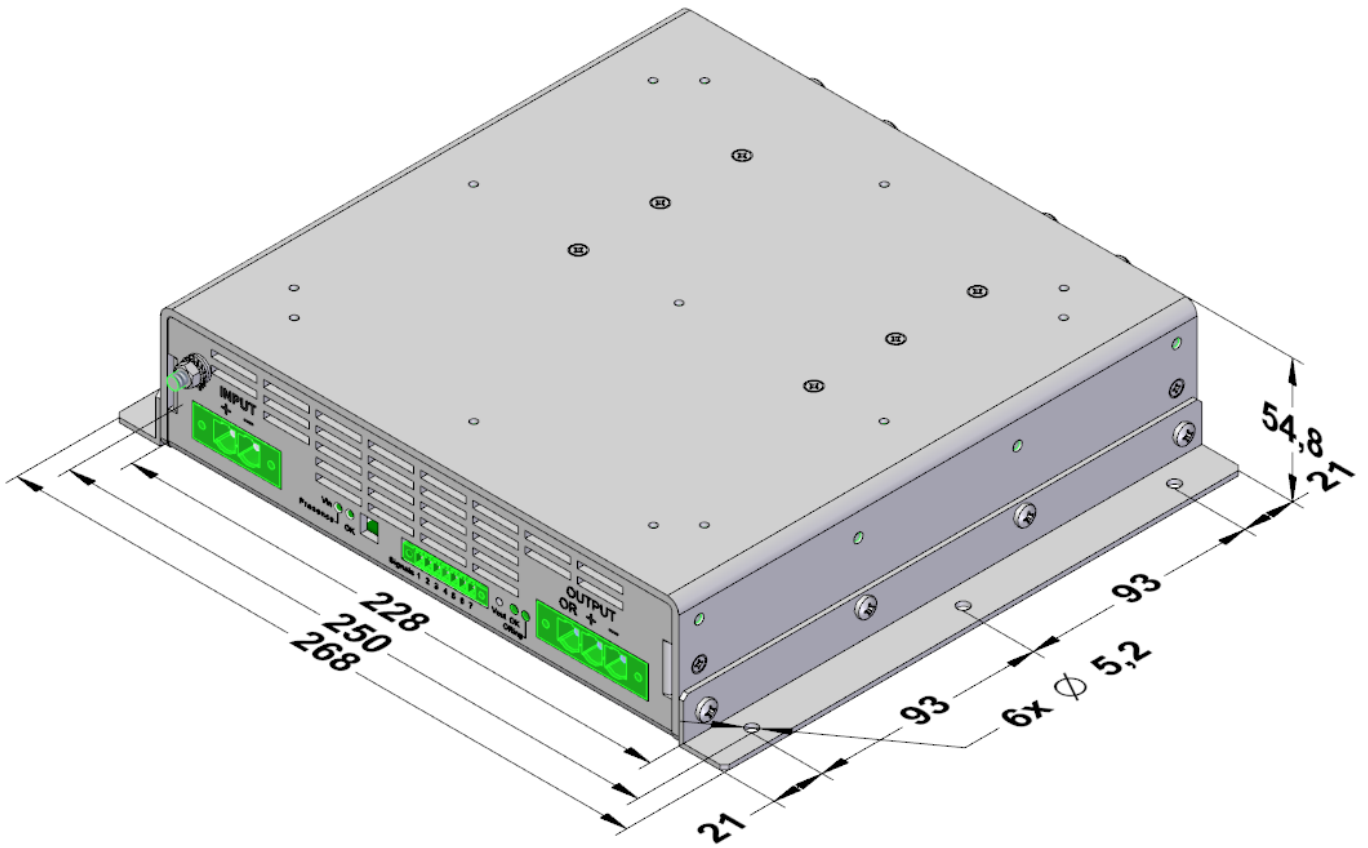

ACCESSORIES

Description	Notes	CODE
Signals mating connector	Phoenix Contact FK-MCP 1,5/ 7-STF-3,81	2601-395
Power mating connector (input)	Phoenix Contact SPC 16/ 2-STF-10,16	2601-606
Power mating connector (output)	Phoenix Contact SPC 16/ 3-STF-10,16	2601-607
Guiding plates for 6U subrack mounting	Screws included	NP-9222
Brackets for 6U subrack mounting	Screws included	NP-9352
2U 19" rackmount tray kit	Screws included	NP-9354

2601-395



2601-606

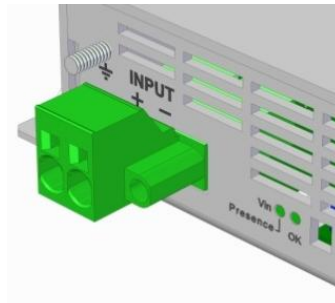

2601-607

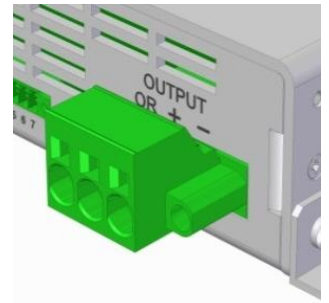



3

NP-9222+NP-9352

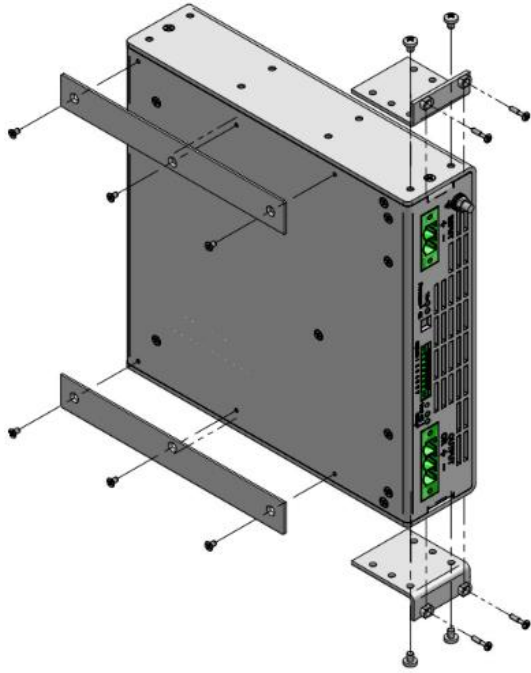

NP-9354

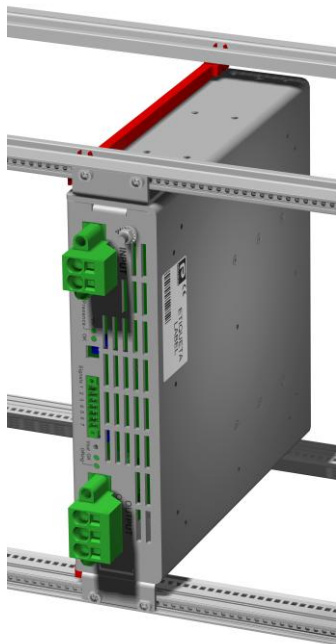
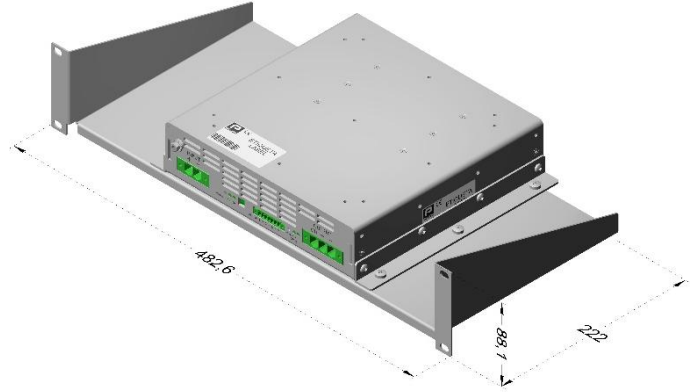



CE|UK CA EU, UKCA DECLARATION OF CONFORMITY

The undersigned, representing the following:

Manufacturer: PREMIUM, S. A.,
Address: C/ Dolors Aleu 19-21, 08908 L'Hospitalet de Llobregat, SPAIN

herewith declares that the product:

Type: DC/DC converter
Models: **CRS-1000-6475 ... 6493**

is in conformity with the provisions of the following EU directives and UK legislation:

2014/35/EU SI 2016 No 1101	Low voltage / The electrical equipment (safety) regulations
2014/30/EU SI 2016 No 1091	EMC / Electromagnetic compatibility regulations
2011/65/EU Annex II and its amendment 2015/863/EU SI 2012 No. 3032	RoHS / Restriction of the use of certain hazardous substances in electrical and electronic equipment

and that standards and/or technical specifications referenced below have been applied:

EN 62368-1: 2020	Safety. Audio/video information and communication technology equipment
EN 61000-6-4: 2019	Generic emission standard
EN 61000-6-2: 2019	Generic immunity standard
EN 50155: 2021	Railway applications. Electronic equipment used on rolling stock material
EN 50121-3-2: 2019 IEC 62236-3-2: 2018	Railway applications. EMC Rolling stock equipment
EN 50121-4: 2019 IEC 62236-4: 2018	Railway applications. EMC of the signalling and telecommunications apparatus

CE marking year: **2018**; UKCA marking year: **2021**

Notes:

For the fulfillment of this declaration the product must be used only for the aim that has been conceived, considering the limitations established in the instructions manual or datasheet.

L'Hospitalet de Llobregat, 08-09-2023

Albert Sole
Technical Director

PREMIUM S.A. is an ISO9001 and ISO14001
certified company by **Bureau Veritas**